



# GCWA NEWSLETTER



June 2005

## PRESIDENT'S CORNER

Thank you GCWA members for the chance to lead an organization comprised of exceptional people doing exceptional work. The work in this case certainly includes the quality of the monthly turnings but also includes the club's many community contributions through our various civic outreach projects. These are indeed, the events that show the quality of our members. These members include the outgoing officers who spent hours of their personal time working to produce the memorable events of the club during the last year.

The biggest news this past month was the Conroe Retreat. For me, the Retreat ranks right up there with the annual SWAT, AAW, and Utah shows on my turning calendar. As usual, the highlights of the weekend were the association with other members, the hands-on instruction, and the food. I believe this was the first year that we passed out a survey asking the attendees what they thought about specific items along with any complaints and suggestions for improvement. A review of the forms indicates that people were overwhelmingly happy with the event and some very perceptive suggestions were included. The complaints were even more interesting and many of the suggestions and complaints will be included in next years Retreat. About a third of the attendees were NEW members and the chief comment by these members had to do with the friendliness and helpfulness of the "experienced" members.

While I hate to start naming names, several people were key to this successful Retreat. **Linda Box** and the other ladies certainly provided great food for all the meals but the highlight was the non-dietetic, between meal snacks. **Jonathan** and **Reggie** managed to find and setup enough lathes to hold classes and keep things running smoothly right through the final cleaning of the facility. **Bill Berry** spent the budget like it was his own money and obtained a lot of tools for **Susan** and **Joan** to raffle off along with a bunch of donations from **Andy Box**. Finally, **Janice** coordinated a lot of loose ends and pulled off another successful Retreat.

I think most of us would agree that there's not much wrong with our club, but everything can be improved. If you have some little (or large) concern that is effecting your enjoyment of the club, please let me know. My email and phone are listed later in this newsletter but if you are truly the shy and bashful type, you can always

send a "snail" mail to 3831 Blue Springs Dr, Houston 77068, I really do want to know.

Our first board meeting of the new officers will be tomorrow night and therefore the committees leads have not yet been determined. We will publish them in the next Mewsletter along with the committee members. The committee lead will typically be one of the board members but we will need the membership's help to complete the committee lists. If you are approached about serving on a committee, please consider helping. Below is a partial listing of the committees:

- a.. Program Committee—
- b.. Refreshments Committee (donuts, drinks, coffee)—
- c.. Meeting Locations Committee—
- d.. Show and Tell—
- e.. Raffle Committee—
- f.. Video Committee—
- g.. Membership Committee—
- h.. Retreat Committee—
- i.. SWAT Representative—
- j.. Web Master—
- k.. Library/Archives—
- l.. Newsletter—

Tom Enloe



*Making goblets at the Spring Retreat*

**June Meeting, June 18, 2005  
Armand Bayou Nature Park  
8500 Bay Area Blvd.  
Pasadena, TX**

## LIBRARY CORNER

by Tom Enloe

The DVDs are here. At the Spring Retreat in Conroe we accepted VHS tape returns and handed out only DVDs. About three quarters of the existing demos have been converted and the rest are in-process. So far, only two people have reported problems with the DVDs and we are working on these. Email or call me if you encounter a problem and I can try to isolate the problem.



*Don Fluker with the 2005 Luna Ford Award Plaque*

## A CLUB CHALLENGE FREEDOM PENS PROJECT

We have not received any pens for the past two months. I hope that now that the retreat has come and gone that we can get back to making some pens for our service people who are away from their families

Pens Received in 2004 = **34,490**

Pens Received in 2005 = **5882**

Total Pens Received = **40,372**

Thanks

Don Fluker

## MEMBERSHIP

Three new members joined GCWA in May. Welcome to:

**Tony Crowsey, Eric Johnson,  
and Ed Wyatt**

## CLUB NEWS & ANNOUNCEMENTS

### New Executive Committee

For those members unfortunate enough to have missed the Spring Retreat, the 2005-06 Officers and Board of Directors were presented to the membership. They are **Tom Enloe** - President/Librarian & SWAT Representative, **Don Fluker** - Vice President/Show & Tell Chairman, **Lane Bradford** - Secretary/Refreshments Chairman, **Robert Frost** - Treasurer, **Janice Levi** - Board Member/Program Chairwoman, **Reggie Keith** - Board Member, **Bill Lewis** - Board Member, **Jay Ebner** - Board Member/Raffles Chairman and **Bill Pottorf** - Board Member/ Meeting Sites Chairman.

### Luna Ford Award

The 2005 Luna Ford Award was presented to **Don Fluker** for his outstanding service to GCWA and the community. There is no doubt in anyone's mind as to whether Don deserves this distinction. He is always ready and willing to take on any new responsibilities and always does a great job. Congratulations Don.

### Show & Tell for May and June

There was no Show & Tell at the May meeting because the many activities at the Retreat just do not allow for the time to conduct the function. There will be a Show & Tell at the June meeting, so be sure to bring your entries.

### Tool Show & Tell at the June Meeting

The Tool Show & Tell will feature Turning Tools, Jigs, Fixtures, Turning Aids, Gages, and any other device that can be adapted toward wood turning. No matter what it is, or how simple or complicated, others will be interested in your ideas and approaches. So, take this opportunity to show it and tell about it.

### GCWA Website

GOT GOLD? Many GCWA members proudly display their work on the world wide web via our website's Gulf Coast Gold gallery. You can too. If you already have pictures of your work in JPEG file format, you can send them to **Dale Barrack** at GCWA1@gulfcoastwoodturners.org, or you can bring your turnings to the June meeting where Ric Taylor will photograph them for you. After June's meeting, we will take a break from photographing for the Gold gallery every month.

### Tool and Wood Swap this Month

One of the popular activities of some of our meetings is a "**Turning Tools Swap**". We are going to do it again at the June meeting. Those of you, who didn't bring your "stuff," to the last toolswap, get it all together, now that you know how it works. If you have any **wood, turning tools or turning sundries** that you want to **SELL or TRADE**, please bring them to the June meeting. Start digging out all those seldom or never used items that are collecting dust. It could be just the tool someone else "needs". There will be tables set up to display all of your items. **Please have all tools marked with your NAME and a PRICE.**

### Retreat Survey

Those who attended the Spring Retreat were asked to complete an Attendance Survey which provided the opportunity to rate its presentation. This was very enlightening and the results will be made available to the membership soon. The Board has decided to expand upon this by asking for a similar survey of those members who, for one reason or other, did not attend the Retreat. From these surveys, we can gain valuable information that should make future Retreats better and possibly improve attendance.

# Reversing Switch for Variable Speed Jet Mini Lathe

By: Mack DeBose

The new Variable Speed Jet Mini Lathe is a welcomed upgrade from the standard Mini Lathe that has been so widely accepted among woodturning enthusiasts. It offers a wide band of speeds within three pulley ranges from 500 RPM to 3000 RPM. This is accomplished by a 1/2 HP DC motor and a SCR controller. Unfortunately, it does not have a spindle reverse function. It would also be nice if the low speed could be reduced to near zero RPM.

The spindle reverse function can be easily added, the zero speed may not be attainable. Further research will determine if the speed reduction can be obtained without damaged the electronics or the motor.

To add the spindle reverse function all that is needed is a DPDT two position toggle switch, some 16 gauge stranded wire, some crimp-on spade terminals and a small electronics enclosure box. This switch has 6 terminals on the back and a bat handle. It has two 'ON' positions with no 'OFF'. Wire the switch as shown below:

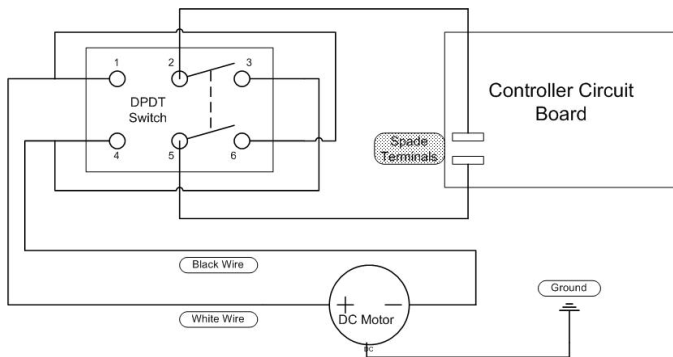

On the back of the DPDT switch, connect wires (preferably soldered) as follows:

- between terminals 1 and 6
- between terminals 3 and 4
- length of wire from terminals 1 & 4 \*
- length of wire from terminals 2 & 5 \*

\* Wire lengths will be determined by where the switch is located in relation to the existing circuit board connectors and the motor leads. Start off with approximately 8" of wire to be cut to length later.

Mount the switch in a small plastic or metal box and extend the wire leads through a hole in the box. If the box is metal, a grommet should be installed in the hole to protect the wires. The box should be as small as possible but still allowing room inside for the body of the switch and wire connections. Mount the box near the controller so that the wire leads can be kept short and unobtrusive. The best position is on the back of the controller and attached with double-sided foam tape. There should be some existing cutouts on the backside of the controller housing that will faci-

tate the routing of the wire leads into the housing without modifying the housing.

Be sure to unplug the power cable from the AC power source. Remove 4 screws from the Controller housing to open it and expose the circuit board.

Determine the lengths required for the 4 leads from the switch. Cut to length, strip ends and crimp on spade connectors as follows:

Wires from terminals 1 & 4 - use male spade terminals

Wires from terminals 2 & 5 - use female spade terminals (fully insulated type)

Disconnect the 2 motor leads from the spade connectors on the Controller Circuit Board. Connect these two wires (black and white) to the male connectors on the wires attached to terminals 1 & 4 of the switch. It is a wise idea to wrap these connections with electrical tape to ensure that there will be no possible electrical shorts.

Connect the 2 wires with the female connectors from terminals 2 & 5 of the switch to the spade terminals on the Controller Circuit Board.

Make sure there are no possibilities for shorts and that it is safe to power up the controller and motor. Apply power and determine at which position the switch lever will be when the spindle has forward rotation. The Forward Rotation position of the switch lever should be UP. If not, disconnect the power; swap the two wires connected to the circuit board, and re-test.

Disconnect the power cable. Use cable ties as necessary to arrange the wires in a neat and orderly manner. Close the Controller housing and re-install the screws.

Reconnect the power cable. The reversing switch should now work properly. DO NOT reverse the spindle while in motion. ALWAYS turn the controller OFF before changing direction of rotation.

BE AWARE too, that reversing the spindle will tend to unscrew a chuck or face plate if not securely tight on the threaded spindle nose.

This modification may have an effect on Jet's warranty for the lathe. There have been no permanent modifications of the lathe, motor or controller so it is reasonable to assume that the warranty will not be affected. If in doubt, the reversing switch can always be removed and the original circuitry re-connected.



Switch mounted on the back of the control box.



## CLASSIFIED ADS

Woodturning related items of interest to GCWA Members listed as a free service.

### FOR SALE

Timeless classic. Everyone dreams of owning one. Now is your opportunity. This lathe will give anyone a deep appreciation of quality, especially those Delta aficionados. This 1944 Delta 1460 lathe is a beauty. Original pristine condition with only two owners in it's lifetime you know that it has been well taken care of. It is sad that it must go to make way for larger pieces of equipment. That will give someone else the joy of ownership. This lathe is rugged enough for anyone and it's timeless qualities make it great for anyone who appreciates great tools. As you can see by the photo, it is in excellent shape and had the original accessories are still intact. The original paper work that comes with the lathe make it a true collectors item. \$669.99. Contact:

Diana  
Gahagan @  
281-685-  
7365.



## Letter from Fleury Sommers of Fleury Galleries

I appreciate the support of the Gulf Coast Woodturners Association in delivering such uniformly high quality work for the recent show at Fleury Gallery. As you know, wood turning has not yet achieved its rightful recognition in the mind of the collector as "art" although it certainly has developed a deep level of museum and curatorial interest. This show and others like it build exposure for the medium, generating collector interest and sales.

Thanks, too, to Bill Berry and Don Fluker who so generously spent their Saturday turning wood at the gallery. This kind of support is so helpful and appreciated.

Based on my own experience, going forward, here are some thoughts that may be of interest. (Please bear in mind, this is entirely personal and may be different from your own experience.)

1.. Wood turning, to be accepted as art, should have no function other than the aesthetic. This means that at least for me, utilitarian objects, beautiful as they may be, do not really belong in an "art" gallery.

2.. The best turnings are sculptural; they have a unique form and aesthetic and convey the sensibility of the turner. They are in a sense, recognizable, in the same way that we recognize a painting by Picasso or another artist.

3.. PATIENCE, PATIENCE, PATIENCE. Some of the most brilliant work here hasn't sold yet. As people learn to "look" at woodturning, I believe they will learn to discern the truly brilliant from the merely competent.

Now to sales. Although it's a truism to say that we always want more sales, in fact, sales were relatively good and they are on-going. Without reference to my notes, Larry Zarra, Don Fluker, Bill Berry, Jim Keller, Paul Kendall, Kevin Turco, Janice Levy and others sold work. Congratulations.

Finally I should say I've never worked with a nicer and more accommodating group of people. On a professional basis, I was proud to show this work. Personally, it was an absolute pleasure to put the show together because of the wonderful personalities of the individuals in your organization.

Many thanks to all of you. Fleury Sommers

## Scenes from the 2005 Spring Retreat



### MENTOR PROGRAM

The following members have volunteered to serve as Club Mentors:

**Jim Keller**-----**(281) 438-1171**

**By Reed**-----**(979) 830-0917**

**Bill Berry** -----**(281) 479-8073**

**Diana Gahagan** **(281) 446-1590**

**Marty Kaminsky** **(281) 339-3297**

**Ernie Bahr** -----**(832) 476-3804**

**Luna Ford**-----**(281) 476-4159**

**Brian Laing**-----**(281) 580-5381**

If you would like to have one of these individuals talk with you about a particular piece, feel free to bring it to the meeting.

## Scheduled Meetings & Events

*Meeting dates and locations are subject to change.*

**June 18, 2005** ~ GCWA Meeting ~ 9:00 AM ~ Armand Bayou Nature Park ~ 8500 Bay Area Blvd., Pasadena, TX  
**June 30, 2005** ~ Board Meeting ~ 7:00 PM ~ Reggie Keith's Office ~ 11391 Meadowglen Ln., Suite D ~ Houston, TX  
**July 16, 2005** ~ GCWA Meeting ~ 9:00AM ~ University of Houston School of Architecture, Bldg. 543 ~ Houston, TX  
**July 22-24, 2005** ~ AAW 2005 Symposium ~ Kansas City, MO  
**\*August 1, 2005** ~ First Monday ~ 7:00 PM ~ The Cutting Edge ~ 11760 S. Sam Houston Pkwy W. ~ 713-981-9228  
**August 8, 2005** ~ Board Meeting ~ 7:00 PM ~ Robert Frost's Home  
**August 20, 2005** ~ GCWA Meeting ~ 9:00AM ~ The Cutting Edge ~ 11760 S. Sam Houston Pkwy W. ~ 713-981-9228  
**September 5, 2005** ~ Board Meeting ~ 7:00 PM ~ Lane Bradford's Home  
**\*September 5, 2005** ~ First Monday ~ 7:00 PM ~ The Cutting Edge ~ 11760 S. Sam Houston Pkwy W. ~ 713-981-9228  
**September 17, 2005** ~ GCWA Meeting & Picnic ~ 9:00 AM ~ 8430 Lake Dr. ~ Chappell Hill, TX  
**Sept. 30 thru Oct. 2, 2005** ~ SWAT 2005 Symposium ~ Wichita Falls, Tx  
**\*October 3, 2005** ~ First Monday ~ 7:00 PM ~ The Cutting Edge ~ 11760 S. Sam Houston Pkwy W. ~ 713-981-9228  
**October 3, 2005** ~ Board Meeting ~ 7:00 PM ~ Don Fluker's Home  
**October 15, 2005** ~ GCWA Meeting ~ 9:00AM ~ Cypress Fairbanks High School ~ 22602 Hempstead Hwy. ~ Cypress, TX  
**\*November 7, 2005** ~ First Monday ~ 7:00 PM ~ The Cutting Edge ~ 11760 S. Sam Houston Pkwy W. ~ 713-981-9228  
**November 7, 2005** ~ Board Meeting ~ 7:00 PM ~ Bill Pottorf's Home  
**\*November 12 & 13, 2005** ~ Armand Bayou Nature Center Fall Festival  
**November 19, 2005** ~ GCWA Meeting ~ 9:00AM ~ The Cutting Edge ~ 11760 S. Sam Houston Pkwy W. ~ 713-981-9228  
**\*December 5, 2005** ~ First Monday ~ 7:00 PM ~ The Cutting Edge ~ 11760 S. Sam Houston Pkwy W. ~ 713-981-9228  
**December 5, 2005** ~ Board Meeting ~ 7:00 PM ~ Dale Barrack's Home  
**December 17, 2005** ~ GCWA Meeting ~ 9:00 AM ~ Hardwood Lumber Company ~ 700 E. 5½ St. ~ Houston, TX  
 \* Events not sponsored by GCWA.

## June Meeting Location

### Armand Bayou Nature Park



## June Meeting Program

**Turning Tools, Jigs, Fixtures and Turning Aids Show & Tell**  
**Turning Tools Swap**

## EXECUTIVE COMMITTEE

Tom Enloe - President/Librarian/  
 SWAT Representative  
 (281) 580-1905  
 tomtom@houston.rr.com

Lane Bradford - Secretary  
 (281) 353-8905  
 bradfwl@swbell.net

Jay Ebner - Board Member  
 (713) 777-7019

Bill Lewis - Board Member  
 (281) 496-5797

Janice Levi - Past President/Board Member  
 (713) 475-2308  
 TJLevi@swbell.net

Bill Pottorf - Board Member  
 (281) 497-3008

Dale Barrack - Website Creative Director  
 (281) 358-8529

Mack DeBose - Newsletter Editor  
 (281) 444-7993

Lmdebose@swbell.net

Don Fluker - Vice President  
 (281) 855-8230

Robert Frost - Treasurer  
 (281) 474-4690

Reggie Keith - Board Member  
 (281) 496-9876

Email: [gcwa@jalepeno.com](mailto:gcwa@jalepeno.com)  
GCWA Websites:  
[www.gulfcoastwoodturners.org](http://www.gulfcoastwoodturners.org)  
<http://go.to/gcwa>

Program Chairman  
**Janice Levi**

GCWA is affiliated with the American Association of Woodturners. GCWA meetings are usually held at 9:00 AM on the 3rd Saturday of each month. Check the Calendar of Events page. Annual dues are \$18 due on January 1. Dues may be mailed to Helen Osteen, 2502 Esther Ave., Pasadena, TX 77502-3239. Make your check payable to GCWA or Gulf Coast Woodturners Assn.

## Internet Web Sites of Interest

American Association of Woodturners: <http://www.woodturner.org>  
Robert Sorby: <http://www.robert-sorby.co.uk/turning.htm>  
Wood Magazine: <http://www.woodmagazine.com>  
The Cutting Edge: <http://www.cuttingedgetools.com>  
Craft Supply: <http://www.woodturnerscatalog.com/index.html>  
Tidewater Turners of Virginia: <http://www.esva.net/~woodturner>  
Fred Holder's More Woodturning: <http://www.fholder.com>  
Exotic Burl: <http://www.exoticburl.com>  
San Diego WoodTurning Center, Inc.: <http://www.sdwoodturning.com>  
Kestrel Creek Gallery: <http://www.kestrelcreek.com>  
Hibdon Hardwoods: <http://www.hibdonhardwood.com>  
Dallas Area Woodturners: <http://www.turningwood.com>  
Woodcraft: <http://www.woodcraft.com>  
Christian Burchard: <http://www.burchardstudio.com>  
Texas Turn or Two: <http://www.texasturnortwo.com>  
Southwest Association of Turners: <http://www.texasturnortwo.com>  
Trent Bosch: <http://www.trentbosch.com>  
Central Texas Woodturners: <http://www.ctwa.org>



Gulf Coast Woodturners  
Association